

MDV Essential

FICHA PRODUCTO



MDV-06
Control incluido de serie



Producto certificado por: **CE**



CARACTERÍSTICAS

Modelo conjunto	MDV ESSENTIAL 26(09)S2.1	MDV ESSENTIAL 35(12)S2	MDV ESSENTIAL 52(18)S2	MDV ESSENTIAL 71(24)S2
Capacidad frigorífica	2,64 kW	3,52 kW	5,28 kW	7,03 kW
Consumo frío	799 W	1.213 W	1.550 W	2.600 W
Capacidad calorífica	2,93 kW	3,81 kW	5,57 kW	7,33 kW
Consumo calor	789 W	1.088 W	1.570 W	2.400 W
Clasificación ErP frío/calor	A++ / A+	A++ / A+	A++ / A+	A++ / A+
Caudal de aire (int.)	434/333/259 m ³ /h	314/430/540 m ³ /h	540/680/840 m ³ /h	662/817/980 m ³ /h
Presión sonora (int.)	21 dB(A)	21 dB(A)	20 dB(A)	36 dB(A)
Caudal de aire (ext.)	1.750 m ³ /h	1.750 m ³ /h	2.100 m ³ /h	3.500 m ³ /h
Presión sonora (ext.)	56 dB(A)	56 dB(A)	56 dB(A)	59 dB(A)
Alimentación	220-240 V / 1 / 50 Hz			
Cableado alimentación (ext.)	(2+T)x1,50 mm ²	(2+T)x1,50 mm ²	(2+T)x1,50 mm ²	(2+T)x2,50 mm ²
Cable interconexión	(4+T)x1,50 mm ²	(4+T)x1,50 mm ²	(4+T)x1,50 mm ²	(4+T)x2,50 mm ²
Tuberías frigoríficas	Ø1/4" / Ø3/8"	Ø1/4" / Ø3/8"	Ø1/4" / Ø1/2"	Ø3/8" / Ø5/8"
Carga fábrica / Carga adicional	0,55 kg / 0,012 kg	0,55 kg / 0,012 kg	1,08 kg / 0,012 kg	1,42 kg / 0,024 kg
Longitud máx. tuberías	25 m	25 m	30 m	50 m
Desnivel máx.	10 m	10 m	20 m	25 m

ESQUEMA CONEXIONES

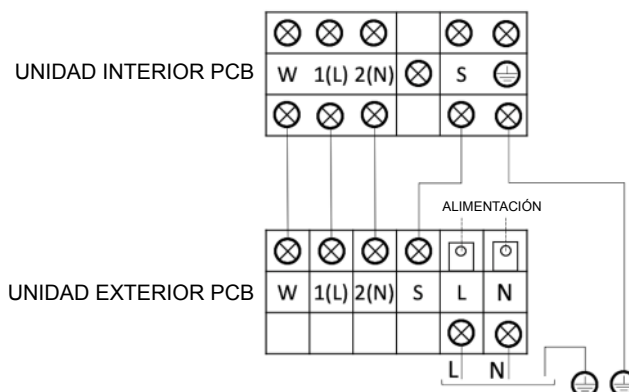

NOTAS:

- (1) Los datos y especificaciones presentes en esta ficha pueden variar sin previo aviso.
- (2) Las imágenes de esta ficha son de carácter orientativo, pudiendo ser diferentes a la máquina final.

DIMENSIONES Y PESO UNIDAD INTERIOR

Modelo	Peso	A	B	C
MDVIM-26(09)-MN8S2	7 kg	715 mm	285 mm	194 mm
MDVIM-35(12)-MN8S2	7,60 kg	805 mm	285 mm	194 mm
MDVIM-52(18)-MN8S2	10 kg	957 mm	302 mm	213 mm
MDVIM-71(24)-MN8S2	12,30 kg	1.040 mm	327 mm	220 mm

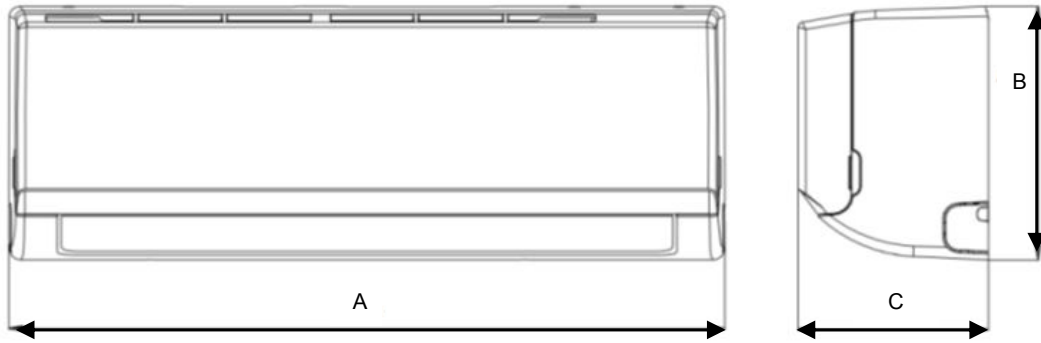

DIMENSIONES Y PESO UNIDAD EXTERIOR

Modelo	Peso	A	B	C
MDVO-26(09)-MN8S2.1	23,20 kg	720 mm	495 mm	270 mm
MDVO-35(12)-MN8S2	23,20 kg	720 mm	495 mm	270 mm
MDVO-52(18)-MN8S2	32,70 kg	805 mm	554 mm	330 mm
MDVO-71(24)-MN8S2	42,90 kg	890 mm	673 mm	342 mm

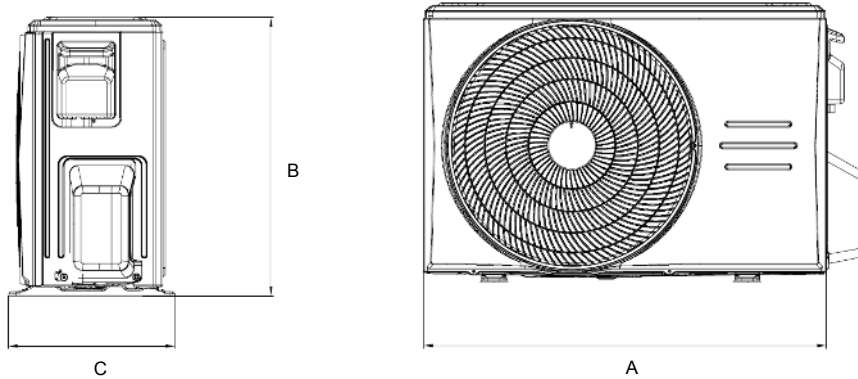

INSTALACIÓN

